



INTERNATIONAL APPLICATION PUBLISHED UNDER THE PATENT COOPERATION TREATY (PCT)

<p>(51) International Patent Classification <sup>5</sup> : <b>A61B 19/00</b></p>	<p><b>A1</b></p>	<p>(11) International Publication Number: <b>WO 93/09727</b> (43) International Publication Date: 27 May 1993 (27.05.93)</p>
--	------------------	--

<p>(21) International Application Number: PCT/US92/09649 (22) International Filing Date: 12 November 1992 (12.11.92) (30) Priority data: 792,001 14 November 1991 (14.11.91) US (60) Parent Application or Grant (63) Related by Continuation US 792,001 (CON) Filed on 14 November 1991 (14.11.91) (71) Applicant (for all designated States except US): WAKE FOREST UNIVERSITY [US/US]; Office of Research Development, 300 South Hawthorne Road, Winston-Salem, NC 27103 (US).</p>	<p>(72) Inventors; and (75) Inventors/Applicants (for US only): ARGENTA, Louis, C. [US/US]; 525 Knob View Drive, Winston-Salem, NC 27104 (US). MORYKWAS, Michael, J. [US/US]; 6147 Spring Forest Drive, Pfafftown, NC 27040 (US). (74) Agents: SIBLEY, Kenneth, D. et al.; Bell, Seltzer, Park &amp; Gibson, P.O. Drawer 34009, Charlotte, NC 28234 (US). (81) Designated States: AT, AU, BB, BG, BR, CA, CH, CS, DE, DK, ES, FI, GB, HU, JP, KP, KR, LK, LU, MG, MN, MW, NL, NO, PL, RO, RU, SD, SE, UA, US, European patent (AT, BE, CH, DE, DK, ES, FR, GB, GR, IE, IT, LU, MC, NL, SE), OAPI patent (BF, BJ, CF, CG, CI, CM, GA, GN, ML, MR, SN, TD, TG).  Published With international search report.</p>
---	--

(54) Title: METHOD AND APPARATUS FOR TREATING TISSUE DAMAGE

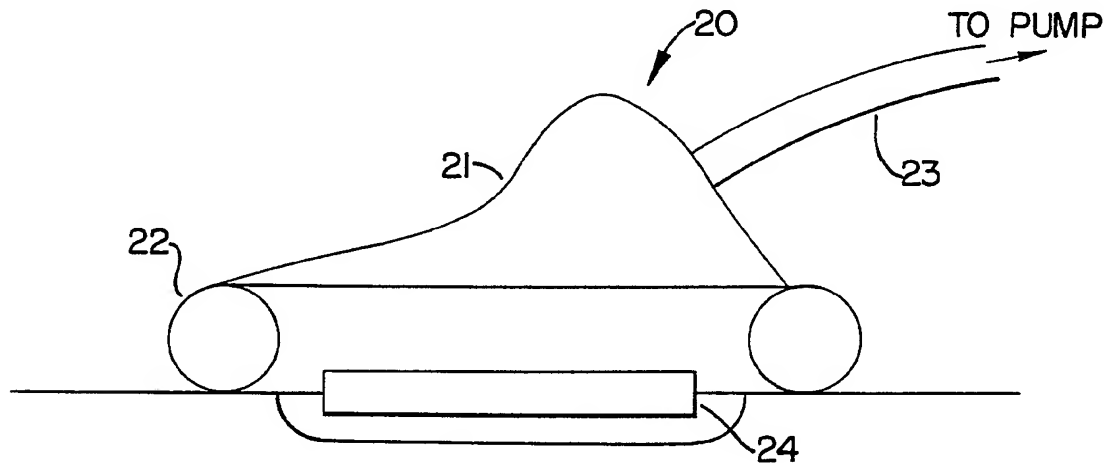

(57) Abstract

The invention disclosed is a method of treating tissue damage comprising applying a negative pressure to a wound sufficient in time and magnitude to promote tissue migration and thus facilitate closure of the wound. The method is applicable to wounds, burns, infected wounds, and live tissue attachments. Configurations of apparatus for carrying out the method are also disclosed

*FOR THE PURPOSES OF INFORMATION ONLY*

Codes used to identify States party to the PCT on the front pages of pamphlets publishing international applications under the PCT.

AT	Austria	FR	France	MR	Mauritania
AU	Australia	GA	Gabon	MW	Malawi
BB	Barbados	GB	United Kingdom	NL	Netherlands
BE	Belgium	GN	Guinea	NO	Norway
BF	Burkina Faso	GR	Greece	NZ	New Zealand
BG	Bulgaria	HU	Hungary	PL	Poland
BJ	Benin	IE	Ireland	PT	Portugal
BR	Brazil	IT	Italy	RO	Romania
CA	Canada	JP	Japan	RU	Russian Federation
CF	Central African Republic	KP	Democratic People's Republic of Korea	SD	Sudan
CG	Congo	KR	Republic of Korea	SE	Sweden
CH	Switzerland	KZ	Kazakhstan	SK	Slovak Republic
CI	Côte d'Ivoire	LI	Liechtenstein	SN	Senegal
CM	Cameroon	LK	Sri Lanka	SU	Soviet Union
CS	Czechoslovakia	LU	Luxembourg	TD	Chad
CZ	Czech Republic	MC	Monaco	TG	Togo
DE	Germany	MG	Madagascar	UA	Ukraine
DK	Denmark	ML	Mali	US	United States of America
ES	Spain	MN	Mongolia	VN	Viet Nam
FI	Finland				

## METHOD AND APPARATUS FOR TREATING TISSUE DAMAGE

### Field of the Invention

This invention relates generally to wound healing, and more specifically is directed at wounds that are unlikely to heal completely under conventional methods.

5

### Background of the Invention

The treatment of open wounds that are too large to spontaneously close has been a troublesome area for many years. Wound closure requires that epithelial and subcutaneous tissue adjacent to the wound migrate toward and eventually close the wound. Some wounds are sufficiently large or infected that they are unable to close spontaneously. In such instances, a zone of stasis, an area in which localized swelling of tissues restricts the flow of blood to these tissues, forms near the surface of the wound. Without sufficient blood flow, the wound is unable to successfully fight bacterial infection and accordingly is unable to close spontaneously.

10

15

20

The most common technique for closure of open wounds has long been the use of sutures or staples. These mechanical closure methods provide tension on the skin tissue at the wound border that encourages

epithelial tissue to migrate toward the wound and cover it. While suturing and stapling of wounds is widely practiced, it has a major drawback: the tensile force required to achieve closure with sutures or staples causes very high localized stresses at the suture insertion points, resulting in the rupture of the tissue at these points. Substantial rupture will eventually cause dehiscence in some wounds, which results in additional tissue loss. Moreover, some infected wounds harden and inflame to such a degree that closure by suturing is not feasible. Wounds not reparable by suturing or stapling generally require prolonged hospitalization, with its attendant high costs, and major surgical procedures, such as grafts of surrounding tissue. Examples of such wounds include large, deep, open wounds, pressure sores resulting from prolonged pressure, ulcers resulting from chronic osteomyelitis, and partial thickness burns that subsequently develop into full thickness burns.

To date, there has been no consistently satisfactory method for treating such wounds. What is needed is a method of closing the wound without the localized stresses that accompany suturing while at the same time treating any infection present in the wound along with a simple apparatus to carry out the method. Such a method and apparatus would reduce hospitalization and increase the probability of wound closure.

#### Summary of the Invention

A first aspect of the invention is a method of treating tissue damage which comprises applying a negative pressure to a wound over an area sufficient to promote the migration of epithelial and subcutaneous tissue toward the wound and for a time period sufficient to facilitate closure of the wound. The method is particularly useful for treating pressure sores.

A second aspect of the invention is a method of treating a burn wound which comprises applying a negative pressure to the burn over an area and for a time sufficient to inhibit progression in the depth of the burn. The method is preferably used on a partial thickness burn soon after its infliction.

A third aspect of the invention is a method of treating tissue damage which comprises applying a negative pressure to a wound for a time sufficient to reduce bacterial density in a wound. A preferred use of this method is its application to a wound for at least 3 days to reduce the bacterial density of an infected wound to the point at which surgical closure can be attempted.

A fourth aspect of the invention is a method of enhancing the attachment of adjacent tissue to a wound which comprises applying a negative pressure to a joined complex of wound and adjacent living tissue at a sufficient magnitude and for a sufficient time to promote the migration of epithelial and subcutaneous tissue toward the complex. A preferred use of this method is enhanced attachment of adjacent tissue to tissues of the wound edges. Another use is enhanced attachment of an open skin graft.

A fifth aspect of the invention is an apparatus for facilitating the healing of wounds which comprises vacuum means for creating a negative pressure on the area of tissue surrounding the wound, sealing means operatively associated with the vacuum means to maintain the negative pressure on the wound, and screen means for preventing overgrowth of tissue in the wound area. A preferred embodiment of the invention comprises a section of open-cell foam configured to be placed over a wound, a flexible tube inserted into the foam section for attachment to a suction pump, and a flexible polymer sheet overlying the foam section and tubing and configured to be adhered to the skin surrounding the wound.

### Brief Description of the Drawings

Figure 1 shows a cross-sectional view of a negative pressure device comprising a open-cell polymer screen, a flexible hose connecting the foam section to a suction pump, and a flexible polymer sheet overlying the foam-hose assembly to provide the necessary seal; and

Figure 2 shows a cross-sectional view of a negative pressure device comprising a porous screen, an inflatable cuff attached to a semi-rigid cup, and a flexible hose extending from a suction pump to a point within the sealed volume of the cup-cuff assembly.

### Detailed Description of the Invention

The present invention includes a method of treating tissue damage which comprises the stages of applying a negative pressure to a wound over an area sufficient to promote migration of epithelial and subcutaneous tissue toward the wound, with the negative pressure being maintained for a time sufficient to facilitate closure of the wound. Wound closure requires that epithelial and subcutaneous tissue migrate from the wound border toward the wound. The use of negative pressure provides tension on this border tissue that causes accelerated tissue migration. It has been observed that the use of the method also causes within the wound increased formation of granulation tissue, a matrix of collagen, fibronectin, and hyaluronic acid carrying macrophages, fibroblasts, and neovasculature that aids in healing.

The method is particularly suited for use on pressure sores. A pressure sore is a wound that develops due to constant compressive pressure on the skin surface and underlying tissue. Blood flow to the compressed tissue is restricted to the extent that the overlying tissue dies and subsequently allows the underlying tissue

to become infected. The decrease of blood flow to the wound prevents a normal immune reaction to fight the infection, the presence of which prevents tissue migration from the wound border. Pressure sores often occur on bedridden patients who are unable to feel the sore or to move sufficiently to relieve the contact pressure. Such wounds can become very serious, requiring extensive and repeated skin grafts; some are even fatal. As described above, application of negative pressure to the sore permits migration of wound border tissue to occur and thus allows sores to heal without these more drastic procedures.

The method can be practiced with the application of substantially continuous negative pressure, where the pressure is relieved only to change the dressing on the wound, or it can be practiced with the use of a cyclic application of pressure in alternate periods of application and non-application. The ratio of duration of application period to non-application period can be as low as 1:10 or as high as 10:1, but is most preferably 1:1. A preferred pattern is 5 minutes of pressure application followed by 5 minutes of relief.

The method is preferably practiced using a negative pressure ranging from 0.01 to 0.99 atmospheres, and more preferably practiced using a negative pressure ranging between 0.5 to 0.8 atmospheres. The time period for use of the method on a wound is preferably at least 12 hours, but can be, for example, 1 day, 2 days, 5 days, 7 days, 14 days, 30 days, or even longer. There is no upper limit beyond which use of the method is no longer beneficial; the method increases the rate of closure up to the time the wound actually closes.

The present invention also includes a method of treating damaged tissue which comprises the steps of applying a negative pressure to a wound for a time and at a magnitude sufficient to reduce bacterial density in the wound. Open wounds are almost always contaminated with

harmful bacteria. Generally a bacterial density of  $10^5$  bacterial organisms per gram of tissue is regarded as infected. (It is generally accepted that at this level of infection, grafted tissue will not adhere to a wound).

5 These bacteria must be killed, either through the wound host's natural immune response or through some external method, before a wound will close. We have observed that application of negative pressure to a wound will reduce the bacterial density of the wound; it is believed that

10 this effect is due to either the bacteria's incompatibility with a negative pressure environment or the increased blood flow to the wound area, as blood brings with it cells and enzymes to destroy the bacteria.

The method can be used to reduce bacterial

15 density in a wound by at least half. More preferably, it can be used to reduce bacterial density by at least 1,000 fold. Most preferably, the method can be used to reduce bacterial density by at least 1,000,000 fold. The ranges of pressure magnitude and application duration are as

20 described above, although Example 3 demonstrates dramatic reduction in wound contamination after a 4-day application of negative pressure. Pressure can be applied continuously or cyclically in the application/nonapplication ratios described above.

25 The present invention also includes a method of treating a burn which comprises the steps of applying a negative pressure to the burn over an area and for a time sufficient to inhibit formation of a full thickness burn. A partial thickness burn, one which has a surface layer

30 of dead tissue and an underlying zone of stasis, is often sufficiently infected that it will transform within 24-48 hours into a full thickness burn, one in which all epidermal structures are destroyed. As explained above, the application of a negative pressure to the wound

35 prevents the infection from becoming sufficiently severe to cause destruction of the underlying epidermal structures. As above, the magnitude, pattern, and



duration of pressure application can vary with the individual wound.

The present invention also provides a method for enhancing the attachment of living tissue to a wound which comprises the steps of first joining the living tissue to the wound to form a wound-tissue complex, then applying a negative pressure to the wound-tissue complex over an area sufficient to promote migration of epithelial and subcutaneous tissue toward the complex, with the negative pressure being maintained for a time period sufficient to facilitate closure of the wound. Attachment of living tissue to a wound is a common procedure that can take many forms. For example, one common technique is the use of a "flap", a technique in which skin tissue from an area adjacent to the wound is detached on three sides but remains attached on the fourth, then is moved onto the wound. Another frequently used technique is an open skin graft in which skin is fully detached from another skin surface and grafted onto the wound. The application of negative pressure to the wound-graft complex reduces bacterial density in the complex and improves blood flow to the wound, thereby improving the attachment of the grafted tissue.

The acceptable ranges of time, magnitude, and application/non-application ratio are as described above. Each of these variables is affected by the size and type of wound.

The present invention also includes an apparatus for facilitating the healing of wounds. The apparatus comprises vacuum means such as a pump for creating a negative pressure on the area of skin surrounding the wound, sealing means such as an adhesive sheet operatively associated with the vacuum means for maintaining negative pressure on the wound by contacting the skin surrounding the wound, and screen means such as an open-cell foam section located within the sealing

means for preventing the overgrowth of tissue in the wound area.

5 The screen means is placed over substantially the expanse of the wound to prevent its overgrowth. The size and configuration of the screen can be adjusted to fit the individual wound. It can be formed from a variety of porous semi-rigid materials. The material must be sufficiently porous to allow oxygen to reach the wound, and sufficiently rigid to prevent wound  
10 overgrowth. Most preferred is the use of an open-cell polymer foam, which permits direct connection of the screen means to the vacuum means through a flexible hose inserted into the foam. Such foam can vary in thickness and rigidity, although it is preferred that a spongy  
15 material be used for the patient's comfort if the patient must lay upon the device during its operation. It can also be perforated to reduce its weight. Another embodiment comprises a section of honeycombed polyethylene sheet cut to the shape of the wound.

20 Possible sealing means include a flexible sealing rim contacting the skin surrounding the wound, a flexible polymer sheet overlying the screen means and the vacuum means and attached to the skin through an adhesive applied to the sheet surface facing the skin, and an  
25 inflatable sealing cuff that conforms to the skin when inflated and that is held in place by the suction of the vacuum means. If an adhesive sheet is used, it must have sufficient adhesion to remain in contact with the skin and form a seal under the negative pressure.  
30 Additionally, it must be sufficiently flexible to overlay the screen means and still conform to the skin around the wound. The sealing means also can include a semi-rigid cup that protects the wound from external contact. For example, a suitable cup-cuff assembly is provided by an  
35 adult CPR mask with an inflatable sleeve.

Suitable vacuum means includes any suction pump capable of providing at least 0.1 pound suction to the

wound, and preferably up to 3 pounds suction, and most preferably up to 14 pounds suction, and a flexible hose that leads from the pump to a point within the pressurized volume created by the sealing means. The pump can be any ordinary suction pump suitable for medical purposes that is capable of providing the necessary suction. The dimension of the tubing are limited only by the pump's ability to provide the suction level needed for operation. A 1/4 inch diameter tube has proven suitable. The vacuum means may operate substantially continuously, or may operate cyclically with alternate periods of application and nonapplication of pressure to the wound.

A preferred embodiment of the invention, shown in Figure 1, comprises a substantially flat section of open cell polyester foam section 10 (Fischer Scientific, Pittsburgh, PA 15219) sufficiently large to cover the wound and thus prevent wound overgrowth, a flexible hollow tube 11 (Fischer Scientific) inserted into the open cell foam section 10 and joined thereto with an adhesive and extending to attach at its opposite end to a Gast Vacuum pump (Fischer Scientific), and an Ioban adhesive sheet 12 (Minnesota Mining and Manufacturing, St. Paul, MN. 55144) overlying the foam section 10 and tubing 11 and adhered to the skin surrounding the wound, thus forming a seal that allows creation of a vacuum when the suction pump operates. Such an apparatus would most preferably be packaged in a sterile condition to ameliorate the need for sterilization of the apparatus prior to use (note that the adhesive sheet 12 could be packaged separately from the foam-tube assembly). A particular advantage of this configuration is its use with pressure sores: the device can be placed in the depths of the wound and the patient can lie upon it without either affecting the utility of the device or further damaging the wound. This becomes critical if the

patient cannot be moved from this posture for other medical reasons.

The present invention is explained further in the following examples. These examples are provided for illustrative purposes only and are not to be taken as limiting.

#### EXAMPLE 1

##### Rate of Wound Healing under Negative Pressure

This example demonstrates the use of negative pressure to increase the rate of healing of full thickness defects by increasing vascularity and the amount of granulation tissue present.

Fifteen-kilogram pigs were obtained and conditioned for 1 week prior to use. The backs of the pigs were shaved and scrubbed for surgery. Two full thickness circular defects were created on the midline of the animals, 2.5 cm in diameter and 1 cm thick. Alginate impressions were taken of each defect to determine its volume. Cefazolin (Kefzol) (500 mg) was administered intramuscularly (antibiotic). The suction devices used, shown in Figure 2, comprised an adult CPR mask (Doug Brown and Associates, Huntington Beach, CA 92648) comprising a semi-rigid cup and inflatable cuff in contact with the skin, an open cell polyester screen overlying the wound, and a flexible 1/4 inch diameter hose (Fischer Scientific) connected by a Nalgene tubing connector to a vacuum pump (Fischer Scientific) and extending through a sealed hole in the cup. Each device was configured such that the suction hose ran from the cup on the animal up through a pulley suspended over the center of the pen and down to a vacuum trap bottle to collect any liquid exudate, then down to the vacuum pump. A suction device was attached over each defect, and suction (2-6 pounds vacuum) was applied to one of the devices. The devices were removed only so that impressions could be made of each defect. This

procedure was continued until the volume of both defects was zero.

5 Table 1 compares the volume of defects over time on individual specimens. Table 2 shows data expressed as the amount of granulation tissue formed per day and as the percent difference in rate of granulation tissue formation. Both data sets show that in all cases the use of negative pressure increased the rate of wound closure and the formation of granulation tissue at a statistically significant rate.

10

#### EXAMPLE 2

##### Rate of Burn Healing under Negative Pressure

This example was designed to demonstrate the use of continuous closed suction for the treatment of deep, partial thickness thermal burns (second degree burns).

15

The backs of 15 kg pigs were shaved and scrubbed for surgery. A 1.5 inch diameter brass rod was heated to 190°C in an oil bath. The rod was pressed onto the pig's skin for 15 seconds following a well-known technique of relating depth of burn to time and temperature. Three burns were created over the spine of each pig, separated by 5 cm intervals. Suction apparatus cups of the configuration described above were placed over two of the burns, with silver sulphadiazine (Silvadine) cream, the standard antibiotic cream applied to human burns prior to excision of burned tissue, applied to the third. Cefazolin (Kefzol) (500 mg) was administered intramuscularly (antibiotic). Suction (2-6 pounds vacuum) was applied to one of the cups. A small (2 mm) punch biopsy was taken of the wounded area and examined histologically for depth of burn.

20

25

30

Table 1. Rate of granulation tissue formation for control and reduced pressure treated full thickness defects in pigs. (Day 0 = surgery)

Animal	Treatment	Defect Volume (cc)												
		Day 0	Day 1	D 2	D 3	D 4	D 5	D 6	D 7	D 8	D 9	D 10	D 11	D 12
1	Suction	5.3			4.3									0
	Control	5.0			4.7									1.2
2	Suction	9.3			8.0									0
	Control	7.2			6.0									0
3	Suction	5.0			4.0									0
	Control	5.0			4.0									1.5
4	Suction	7.0								6.0	2.0			0
	Control	7.0								6.0	4.0			2.0
5	Suction	6.0								5.0	1.0			0
	Control	6.0								6.0	3.0			2.0

Table 2. Rate of granulation tissue formation for control and reduced pressure treated full thickness defects in pigs.

Animal	Granulated Treatment	Tissue/Day(cc)	% Increase*
1	Suction	0.48	26.3
	Control	0.38	
2	Suction	1.16	28.9
	Control	0.90	
3	Suction	0.58	75.8
	Control	0.33	
4	Suction	0.71	65.1
	Control	0.43	
5	Suction	0.71	65.1
	Control	0.43	

\* (Suction-Control)/Control

Table 3. Rate of reduction in bacterial density for control and reduce and pressure treated pigs (n=5).

Log Organisms Per Gram Tissue

eatment	Day 0	Day 1	Day 2	Day 3	Day 4	Day 5	Day 7
ontrol	Mean 8.44 SD ±.38	8.04 ±.13	8.17 ±.98	7.13 ±.15	7.13 ±.24	8.82 ±1.12	7.08 ±.52
cuum	Mean 7.69 SD ±.83	7.36 ±.84	7.37 ±1.40	6.79 ±.55	6.43 ±.45	3.98 ±3.46	4.32 ±3.74



Biopsies were analyzed by a dermatopathologist who was not told the nature of the study. It was concluded that the suctioned tissue specimens were healthier and healing more quickly than non-suctioned specimens.

### EXAMPLE 3

#### Reduction of Bacterial Density under Negative Pressure

This example illustrates the effects of continuous closed suction on the bacterial density of infected tissue.

Fifteen-kilogram pigs were shaved and prepared for surgery. Two 2.5 cm diameter defects were created on the dorsum of each pig using sterile technique, with a 7.5 cm interval retained between the edges of the defects. Hemostasis was obtained by electrocautery. One ml of culture broth containing  $10^8$  Staph. aureus organisms was injected just beneath the surface tissue in the center of each wound. Suction cups of the configuration described above were placed over each defect, and a T-shirt was placed over the animal. Suction (2-6 pounds vacuum) was applied 24 hours after surgery to only one of the defects, allowing each animal to act as its own control. No antibiotics were given during the course of the study.

Each day, a small (3 mm biopsy punch) piece of granulation tissue was removed from the center of each defect. The number of organisms present in the tissue was determined by weighing the tissue, homogenizing the tissue, serially diluting the supernatant, and plating the diluted supernatant on blood agar plates. Samples of the original broth were treated in an identical manner to determine effects of mechanical manipulations on bacteria viability. The procedure was performed until the wounds were healed.

Table 3 compares the bacterial density of treated wounds and control wounds over time. The data is expressed as the mean log of the number of viable organisms per gram of tissue as a function of time. Clearly, the application of negative pressure increases the rate at which bacteria are destroyed. Using  $10^5$  organisms per gram of tissue as a baseline for infection, the data show that on average a suctioned wound was disinfected after 4 days of treatment, while the average non-treated wound was still infected after 7 days.

#### EXAMPLE 4

##### Treatment of Pressure Sore With Negative Pressure

Mr. L.J. is a 45-year-old diabetic male who has been a paraplegic as the result of a gunshot wound for 12 years. He has a history of recurrent right ischeal fossa pressure sore and right trochanteric pressure ulcer. L.J. was admitted to the hospital for treatment and closure of the pressure sores. A flap was placed onto the wound and secured with sutures and staples.

The incisions of the flap dehisced, resulting in a large, open wound. The tissues of the flap were very edematous and indurated. Nine days after the flap was detached, a negative pressure device was placed over the wound. The device comprised an open-cell polyester foam section (Fischer Scientific) approximately 1/2 inch in thickness attached to a suction pump by a flexible hose (Fischer Scientific) and covered and sealed by Ioban polymer sheet (Minnesota Mining and Manufacturing, St. Paul, MN 55144). A continuous vacuum of 5 psi was applied to the wound. The design of the device allowed the patient to lay comfortably on the device during operation.

The depth of the wound decreased dramatically. The devices were changed and the wound examined on a three times per week basis. Reduced pressure treatment

was continued for 6 weeks, at which time the wound was healed.

#### EXAMPLE 5

##### Treatment of Pressure Sore With Negative Pressure

5                   Mr. W.E. is a 51-year-old male who had both  
legs amputated at the hip approximately 20 years ago. He  
was afflicted with a large pressure sore in the buttocks  
region. The pressure sore had been present 7 months and  
measured 8 inches laterally and 3 inches in its greatest  
10                   width. An open cell foam reduced pressure device as  
described in Example 4 was placed over the wound and a  
negative pressure of 5 psi was applied cyclically in  
alternate periods of 5 minutes on, 5 minutes off. The  
open cell foam device was used as the patient was lying  
15                   on the device. The device was changed on a three times  
per week schedule.

                  After 5 weeks of treatment, the wound measured  
3 inches laterally and 1.5 inches at its greatest width.  
At that point the wound was essentially healthy  
20                   granulation tissue that accepted a cultured keratinocyte  
allograft and healed completely.

#### EXAMPLE 6

##### Treatment of Wound Dehiscence With Negative Pressure

                  Mr. C.L. is a 50-year-old male who had  
25                   undergone a colostomy revision through a midline  
laparotomy. He was readmitted to the hospital for wound  
dehiscence and evisceration following forceful coughing.  
The abdominal wall was closed with Prolene mesh coverage.  
Six weeks after placement of the Prolene mesh, the wound  
30                   was still open and measured 28 cm by 23 cm with sparse  
granulation tissue grown through the Prolene mesh. A  
large reduced pressure cup device of the type described  
in Example 1 with an underlying porous Aquaplast sheet

(WFR/Aquaplast Corp., Wyckoff, NJ 07481) was placed on the Prolene mesh/wound surface and the space closed with a tent of Ioban. Five psi of continuous negative pressure was applied. The device was changed three times  
5 per week.

After 6 days, granulation tissue had grown through the Prolene mesh, totally covering the mesh. The patient was taken to the operating room where the surrounding tissue was undermined and grafted onto the  
10 wound to partially close the defect. Split thickness skin grafts were used to cover the remainder of the defect, and were placed on the bed of granulation tissue. The wound accepted 80 % of the grafts, and the remaining areas closed with dressing changes alone.

15

**EXAMPLE 7****Treatment of Ankle Osteomyelitic Ulcer With Negative Pressure**

Mr. R.F. is a 39-year-old white male who had severe trauma to his left lower extremity secondary to a  
20 motor vehicle accident 10 years ago. He had contracted chronic osteomyelitis and an open ulcer with exposed bone of his left lateral ankle (lateral malleolar ulcer). Necrotic soft tissue and bone were surgically removed from the ankle. The patient was placed on a 2-1/2 week  
25 course of antibiotics. The day after surgery, a reduced pressure device of the type described in Example 1 was placed over the wound, and a negative pressure of 5 psi was applied. The device was changed on a three times per week schedule. After 14 days of treatment, the wound was  
30 smaller and filled with granulation tissue. A split thickness skin graft was placed over the center of the defect and healed primarily.

**EXAMPLE 8**Treatment of Burn With Negative Pressure

5 Patient B. is admitted with second and third  
degree burns over the face and upper extremities,  
including both hands, as a result of a house fire. A  
large mitten-shaped reduced pressure device of the type  
described in Example 4 is placed over the patient's right  
hand, with open cell foam inserts placed between the  
10 fingers to apply reduced pressure to the interdigit  
spaces. Three pounds of vacuum is applied cyclically in  
a pattern of 5 minutes on, 5 minutes off. The device is  
changed on a three times per week schedule. Treatment is  
continued until the necrotic tissue sloughs off or is  
excised, followed by split thickness skin graft  
15 placement.

The foregoing examples are illustrative of the  
present invention, and are not to be construed as  
limiting thereof. The invention is defined by the  
following claims, with equivalents of the claims to be  
20 included therein.

## THAT WHICH IS CLAIMED IS:

1. A method of treating tissue damage which comprises the steps of:

5 applying a negative pressure to a wound over an area sufficient to promote migration of epithelial and subcutaneous tissue toward the wound, with said negative pressure being maintained for a time sufficient to facilitate closure of the wound.

2. A method according to claim 1, in which said negative pressure is maintained for a time sufficient to permit the formation of granulation tissue in the wound.

3. A method according to claim 1, in which said wound is a pressure sore.

4. A method according to claim 1, in which said negative pressure is between 0.01 and 0.99 atmospheres.

5. A method according to claim 1, in which said negative pressure is between 0.5 and 0.8 atmospheres.

6. A method according to claim 1, in which said time is at least 12 hours.

7. A method according to claim 1, in which said time is at least 3 days.

8. A method according to claim 1, in which said pressure is applied substantially continuously.

9. A method according to claim 1, in which said negative pressure is cyclically applied in alternate periods of application and non-application.

10. A method according to claim 9, in which the ratio of said period of application to said period of non-application is at least 10:1.

11. A method according to claim 9, in which the ratio of said period of application to said period of non-application is at least 1:1.

12. A method according to claim 9, in which the ratio of said period of application to said period of non-application is at least 1:10.

13. A method of treating a burn which comprises the steps of:

5                   applying a negative pressure to said burn for a time sufficient to inhibit formation of a full thickness burn.

14. A method according to claim 13, in which said burn is a partial thickness burn.

15. A method according to claim 13, in which said time is at least 12 hours.

16. A method according to claim 13, in which said time is at least 3 days.

17. A method according to claim 13, in which said negative pressure is between 0.01 and 0.99 atmospheres.

18. A method according to claim 13, in which said negative pressure is between 0.5 and 0.8 atmospheres.

19. A method according to claim 13 in which said negative pressure is applied substantially continuously.

20. A method according to claim 13, in which said negative pressure is cyclically applied in alternate periods of application and non-application.

21. A method according to claim 20, in which the ratio of said period of application to said period of non-application is at least 10:1.

22. A method according to claim 20, in which the ratio of said period of application to said period of non-application is at least 1:1.

23. A method according to claim 20, in which the ratio of said period of application to said period of non-application is at least 1:10.

24. A method of treating damaged tissue which comprises the steps of:

5           applying a negative pressure to a wound at a magnitude and for a time sufficient to reduce bacterial density in said wound.

25. A method according to claim 24, in which said bacterial density is reduced by at least half.

26. A method according to claim 24, in which said bacterial density is reduced by at least 1,000 fold.

27. A method according to claim 24, in which said bacterial density is reduced by at least 100,000 fold.



28. A method according to claim 24, in which said negative pressure is applied for at least 12 hours.

29. A method according to claim 24, in which said negative pressure is cyclically applied in alternate periods of application and non-application:

30. A method according to claim 24, in which said negative pressure is applied at between 0.01 and 0.99 atmospheres.

31. A method of enhancing the attachment of living tissue to a wound which comprises the steps of:

joining said living tissue to said wound to form a wound-tissue complex, and

5                   applying a negative pressure to said wound-tissue complex over an area sufficient to promote migration of epithelial and subcutaneous tissue toward said complex, with said negative pressure being  
10                   maintained for a time period sufficient to facilitate closure of the wound.

32. A method according to claim 31, in which said living tissue to be attached is a skin graft.

33. A method according to claim 31, in which said living tissue is a flap formed from adjacent tissue.

34. A method according to claim 31, in which said negative pressure is applied for at least 12 hours.

35. A method according to claim 31, in which said negative pressure is cyclically applied in alternate periods of application and non-application.

36. A method according to claim 31, in which said negative pressure is applied at between 0.01 and 0.99 atmospheres.

37. An apparatus for facilitating the healing of wounds, comprising:

vacuum means for creating a negative pressure on the area of skin including and surrounding the wound;  
5 and

sealing means operatively associated with said vacuum means for maintaining said negative pressure on said wound by contacting the skin surrounding said wound.

38. An apparatus according to claim 37, which further includes screen means connected to said vacuum means for preventing the overgrowth of tissue in the wound area.

39. An apparatus according to claim 37, in which said screen means is a structure comprised of an open-cell polymer foam.

40. An apparatus according to claim 37, in which said screen means is a flat, porous, semi-rigid member.

41. An apparatus according to claim 37, in which said sealing means includes a flexible sealing rim in contact with said skin surrounding said wound.

42. An apparatus according to claim 37, in which said sealing means is a flexible polymer sheet overlying said screen means and said vacuum means, said polymer sheet having adhesive on at least the surface  
5 facing the wound to attach and seal said polymer sheet to said surrounding skin.

43. An apparatus according to claim 37, in which said sealing means includes a sealing cuff in contact with said skin surrounding the wound.

44. An apparatus according to claim 43, in which said sealing cuff is inflatable.

45. An apparatus according to claim 37 in which sealing means includes a semi-rigid cup configured to protect said wound from external contact.

46. An apparatus according to claim 37, in which said vacuum means includes pump means capable of providing at least 0.1 pounds suction.

47. An apparatus according to claim 37, in which said vacuum means includes a pump means capable of providing at least 3 pounds suction.

48. An apparatus according to claim 37, in which said vacuum means includes a pump means capable of providing at least 14 pounds suction.

49. An apparatus according to claim 37, in which said vacuum means operates continuously.

50. An apparatus according to claim 37, in which said vacuum means operates cyclically to provide periods of application and non-application of suction.

51. An apparatus for facilitating the healing of wounds comprising:

an open cell polymer foam section configured to overlie a wound; and

5 a flexible tube having an inlet end and an outlet end, said inlet end inserted into said open cell polymer foam section.

52. An apparatus according to claim 50, which is in an aseptic package.

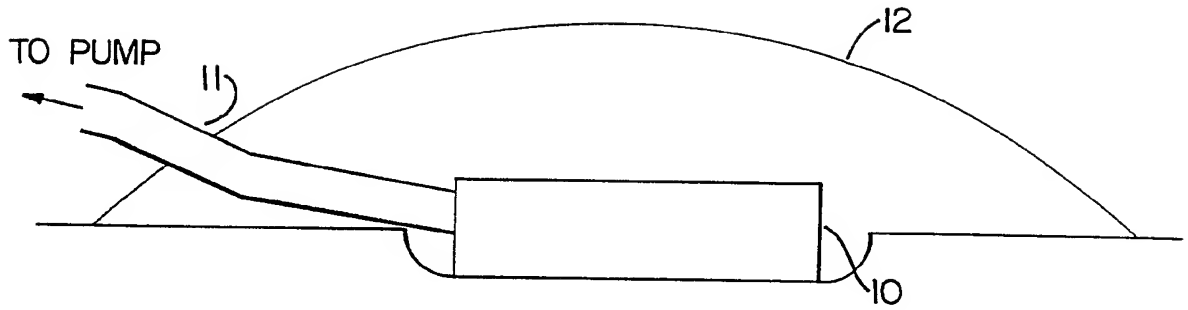

FIG. 1.

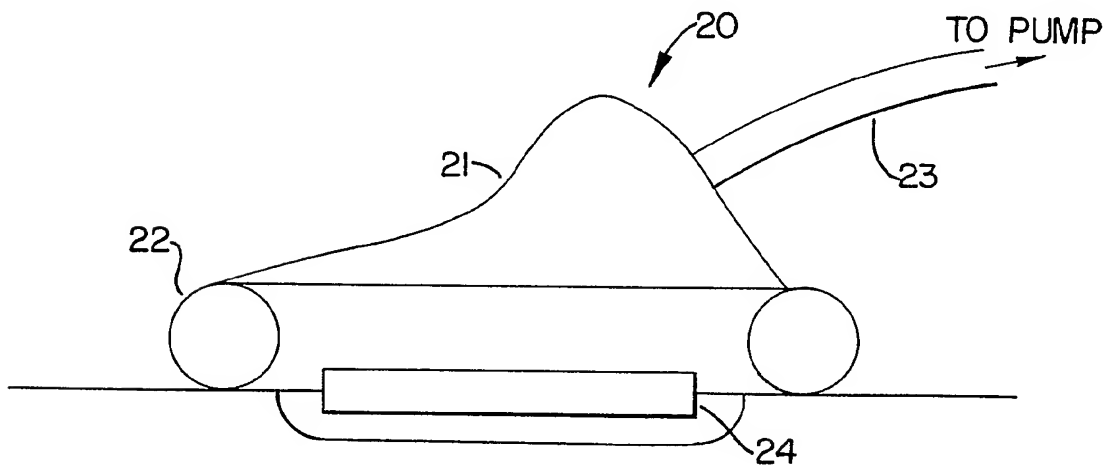

FIG. 2.

INTERNATIONAL SEARCH REPORT

PCT/US92/09649

**A. CLASSIFICATION OF SUBJECT MATTER**

IPC(5) :A61B 19/00

US CL :128/898

According to International Patent Classification (IPC) or to both national classification and IPC

**B. FIELDS SEARCHED**

Minimum documentation searched (classification system followed by classification symbols)

U.S. : 128/898 128/897-899 602/42-53

Documentation searched other than minimum documentation to the extent that such documents are included in the fields searched

Electronic data base consulted during the international search (name of data base and, where practicable, search terms used)

**C. DOCUMENTS CONSIDERED TO BE RELEVANT**

Category*	Citation of document, with indication, where appropriate, of the relevant passages	Relevant to claim No.
X	US,A, 3,874,387 (Barbieri) 01 April 1975 See entire document.	37,41,43
X	US,A, 4,382,441 (Svedman) 10 May 1983 See entire document.	51
A	US,A, 3,367,332 (Groves) 06 February 1968 See entire document.	1-52
A	US,A, 3,026,874 (Stevens) 27 March 1962 See entire document.	1-52
A	US,A, 3,896,810 (Akiyama) 29 July 1975 See entire document.	1-52

Further documents are listed in the continuation of Box C.  See patent family annex.

* Special categories of cited documents:	"T" later document published after the international filing date or priority date and not in conflict with the application but cited to understand the principle or theory underlying the invention
"A" document defining the general state of the art which is not considered to be part of particular relevance	"X" document of particular relevance; the claimed invention cannot be considered novel or cannot be considered to involve an inventive step when the document is taken alone
"E" earlier document published on or after the international filing date	"Y" document of particular relevance; the claimed invention cannot be considered to involve an inventive step when the document is combined with one or more other such documents, such combination being obvious to a person skilled in the art
"L" document which may throw doubts on priority claim(s) or which is cited to establish the publication date of another citation or other special reason (as specified)	"&" document member of the same patent family
"O" document referring to an oral disclosure, use, exhibition or other means	
"P" document published prior to the international filing date but later than the priority date claimed	

Date of the actual completion of the international search: 28 DECEMBER 1992  
 Date of mailing of the international search report: 30 -

Name and mailing address of the ISA/  
 Commissioner of Patents and Trademarks  
 Box PCT  
 Washington, D.C. 20231

Facsimile No. NOT APPLICABLE

Authorized officer

JOHN LACYK

Telephone No. (703) 308-0858

## INTERNATIONAL SEARCH REPORT

International application No.  
PCT/US92/09649

C (Continuation). DOCUMENTS CONSIDERED TO BE RELEVANT

Category*	Citation of document, with indication, where appropriate, of the relevant passages	Relevant to claim No.
A	US,A, 3,954,105 (Nordby et al.) 04 May 1976 See entire document.	1-52
A	US,A, 4,112,947 (Nehring) 12 September 1978 See entire document.	1-52
A	4,224,945 (Cohen) 30 September 1980 See entire document.	1-52
A	US,A, 4,250,882 (Adair) 17 February 1981 See entire document.	1-52
A	US,A, 4,834,110 (Richard) 30 May 1989 See entire document.	1-52